

**OVERVIEW**

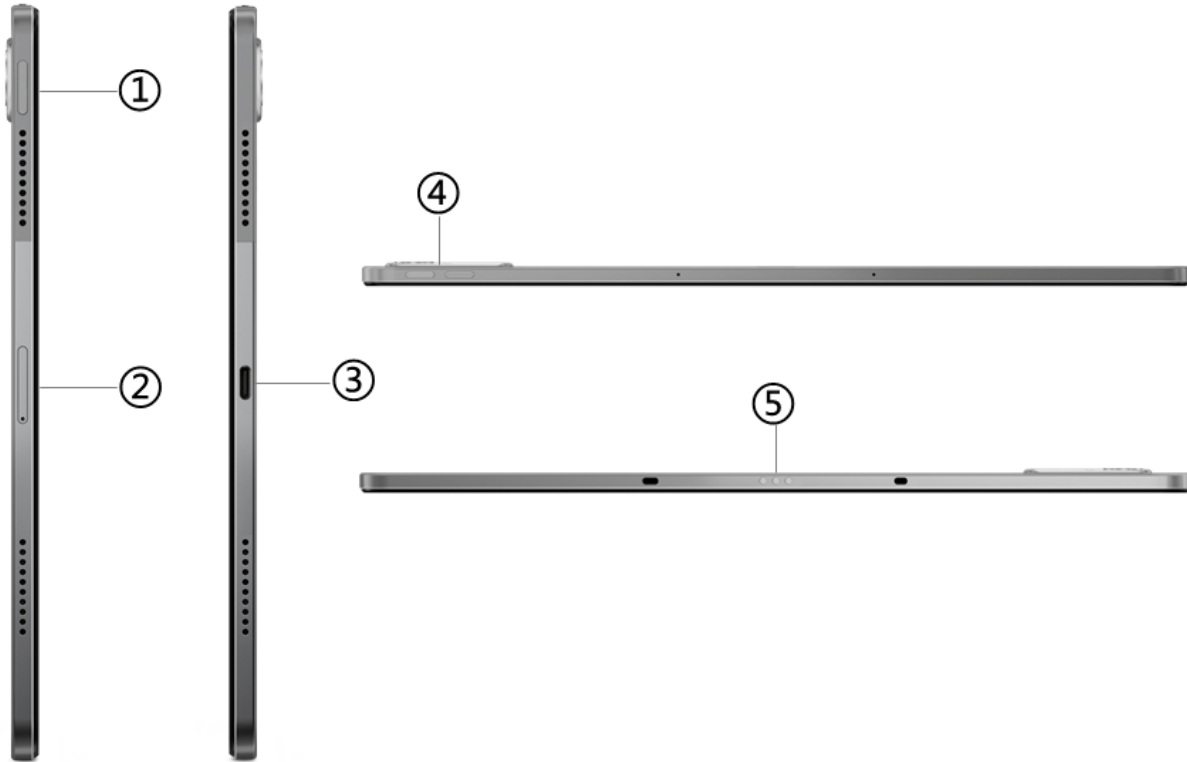

1. Power button (with fingerprint reader)	4. Volume buttons
2. microSD card slot	5. Pogo pin connector (3-point)
3. USB-C 2.0	

Notes:

- 3-point pogo pin connector is used to connect Lenovo Keyboard Pack for Tab P12. Keyboard pack availability varies by country/region.

## PERFORMANCE

### Processor

#### Processor Family

MediaTek Processor

#### Processor

Processor Name	Cores	Max Frequency	Processor Graphics
MediaTek Dimensity 7050	Octa-core 2x A78 + 6x A55	A78@2.6 GHz A55@2.0 GHz	Arm Mali-G68

### Operating System

#### Operating System<sup>[1]</sup>

Android™ 13 or later

Notes:

[1] Expect Android™ 14 and Android™ 15 OS upgrades and four years of security updates until 2027. For the latest software upgrade information, please visit <https://support.lenovo.com/solutions/ht501098>.

### Graphics

#### Graphics

Arm Mali-G68

### Chipset

#### Chipset

MediaTek SoC (System on Chip) platform

### Memory

#### Max Memory

- 4GB soldered memory, not upgradable
- 8GB soldered memory, not upgradable

#### Memory Type

LPDDR4x

### Storage

#### Storage Support

- 128GB uMCP (UFS-Based MCP, UFS 2.2)
- 256GB uMCP (UFS-Based MCP, UFS 2.2)
- microSD card, supports up to 1TB (exFAT)

#### Storage Type

Disk Type	Interface	Offering
Flash Memory	UFS 2.2	128GB / 256GB

### Removable Storage

#### Card Reader

microSD card slot

### Multi-Media

#### Speakers

Quad JBL® speakers, sound by JBL®, 1W x4, optimized with Dolby Atmos®

#### Microphone

Dual-microphone array

#### Camera

Front 13.0MP, f/2.2, 122° FoV (field of view) fixed focus, video recording 4K@30fps, 1080p@30fps, 720@30fps, face unlock  
 Rear 8.0MP, f/2.2, 86.2° FoV, autofocus, video recording 1080p@30fps, 720@30fps; single LED flashlight

**VoiceCall**

No support

**Sensor**

**Vibration Motor**

No support

**Sensors**

- Accelerometer (G) sensor
- Gyroscope sensor
- Hall sensor
- RGB sensor
- e-Compass

**Battery**

**Battery**

Integrated Li-Polymer 10200mAh (typical) battery

**Max Battery Life<sup>[1]</sup>**

Online video playback: 8.79 hr

Web browsing: 10 hr

Notes:

[1] All battery life claims are approximate and based on internal testing under optimal laboratory and network conditions. Actual battery performance will vary depending on numerous factors including product configuration and usage, software, operating conditions, wireless functionality, power management settings, screen brightness and other factors. The maximum capacity of the battery will naturally decrease with time and usage.

**Power Adapter**

**Power Adapter**

10V/2A (20W) AC adapter, 100-240V, 50-60Hz

**DESIGN**

**Display**

**Display**

Size	Resolution	Touch	Type	Brightness	Surface	Aspect Ratio	Contrast Ratio	Color Gamut	Refresh Rate	Viewing Angle (L/R/U/D)	Key Features
12.7"	3K (2944x1840)	Multi-touch	LTPS	400nits	Anti-fingerprint	16:10	1500:1	96% DCI-P3	60Hz	85° / 85° / 85° / 85°	273 PPI, Corning® Gorilla® Glass 3

**Touchscreen**

In-cell multi-touch, supports 10-point touch

**Input Device**

**Pen**

- Lenovo® Tab Pen Plus, 4096 levels of pressure sensitivity, tilt detection, palm rejection
- No pen (purchase separately)<sup>[1]</sup>

Notes:

[1] For details upon pen compatibility, please check the file "Lenovo® Android™ Tablet - Option Compatibility Matrix" from <https://support.lenovo.com/solutions/accs-guide>. Pen availability may vary by country / region.

**Mechanical**

**Dimensions (WxDxH)<sup>[1]</sup>**

293.37 x 190.76 x 6.9 mm with camera bump 8.42 mm (11.55 x 7.51 x 0.27 - 0.33 inches)

**Weight<sup>[2]</sup>**

Around 615 g (1.36 lbs)

**Case Color\*\***

- Oat, dual-tone design
- Storm grey, dual-tone design

**Case Material**

Metal

**Buttons**

- Power button
- Volume buttons

Notes:

[1] The system dimensions may vary depending on configurations.

[2] The system weight is approximate and based on results in Lenovo® lab, which varies depending on the source of component, variance of the distribution of each component, and manufacturing process. It may not be the exact weight for each specific model.

## CONNECTIVITY

### Network

**WLAN + Bluetooth®**

Wi-Fi® 6, 802.11ax 2x2 Wi-Fi® + Bluetooth® 5.1

**WWAN**

No support

**Cellular Bands**

No support

**Wi-Fi® Direct**

Support

**Wi-Fi® Display**

Support

**Location Services**

GPS + GLONASS + Galileo

### Ports<sup>[1]</sup>

**Standard Ports**

- 1x USB-C® 2.0 (support data transfer and charging)
- 1x microSD card slot
- 1x Pogo pin connector (3-point)<sup>[2]</sup>

Notes:

[1] The transfer speed of following ports will vary and, depending on many factors, such as the processing speed of the host device, file attributes and other factors related to system configuration and your operating environment, will be slower than theoretical speed.

USB 2.0: 480 Mbit/s;

USB 3.2 Gen 1 (SuperSpeed USB 5Gbps, formerly USB 3.0 / USB 3.1 Gen 1): 5 Gbit/s;

USB 3.2 Gen 2 (SuperSpeed USB 10Gbps, formerly USB 3.1 Gen 2): 10 Gbit/s;

USB4® 20Gbps / USB 3.2 Gen 2x2 (SuperSpeed USB 20Gbps): 20 Gbit/s;

USB4® 40Gbps (USB 40Gbps): 40 Gbit/s;

Thunderbolt™ 3/4: 40 Gbit/s.

[2] 3-point pogo pin connector is used to connect [Lenovo® Keyboard Pack for Tab P12](#). Keyboard pack availability varies by country/region.

## SECURITY & PRIVACY

### Security

## Fingerprint Reader

Touch style fingerprint reader integrated in power button

# SERVICE

## Warranty

### Base Warranty\*\*<sup>[1]</sup>

- 1-year carry-in service
- 1-year mail-in service
- 1-year courier service
- 1-year courier or mail-in service
- 2-year (1-yr battery) carry-in service
- 2-year (2-yr battery) carry-in service
- 2-year (1-yr battery) courier service
- 2-year (2-yr battery) courier or carry-in service
- 3-year (1-yr battery) courier service

Notes:

[1] For warranty upgrade service, please go to <https://smartfind.lenovo.com/services>. To learn more details of warranty policy, please access <https://support.lenovo.com/warrantylookup/warrantypolicy>.

# ACCESSORIES

## Bundled Accessories

### Bundled Accessories\*\*\*<sup>[1]</sup>

- Grey folio case
- Lenovo® Keyboard Pack for Tab P12<sup>[2]</sup>
- Lenovo® Tab Pen Plus
- Moto Buds
- None

Notes:

[1] For more compatible accessories, please check the file "Lenovo® Android™ Tablet - Option Compatibility Matrix" from <https://support.lenovo.com/solutions/accs-guide>.

[2] Lenovo® Keyboard Pack for Tab P12, one piece touchpad 62 x 105 mm (2.44 x 4.13 inches)

# OPERATING REQUIREMENTS

## Operating Environment

### Temperature

Operating: 0°C (32°F) to 40°C (104°F)

# CERTIFICATIONS

## Green Certifications<sup>[1]</sup>

### Green Certifications

- ENERGY STAR® 8.0
- ErP Lot 6/26
- RoHS compliant

Notes:

[1] The items listed under the "Green Certifications" section may not only refer to certification but also registration or self-declaration. For ESG & regulatory compliance documents, please visit <https://compliance.lenovo.com>.

## Other Certifications

### Other Certifications

- TÜV Rheinland® Flicker Free
- TÜV Rheinland® Full Care Display 3.0 Certification

## SOFTWARE

### Preinstalled Software

#### Preinstalled Software<sup>[1][2]</sup>

- Chrome
- Entertainment Space
- Files by Google
- Gallery Go by Google Photos
- Gmail
- Google
- Google Docs
- Google Drive
- Google Duo
- Google Kids Space
- Google Lens™
- Google Maps
- Google One
- Google Play
- Google Podcasts
- Google Sheets
- Google TV
- Lenovo® Freestyle
- Lenovo® Vantage
- Messages
- MyScript® Calculator
- Nebo®
- Recorder
- WPS
- YouTube
- YouTube Kids
- YouTube Music

#### Notes:

[1] Actual application availability varies by country/region.

[2] Books and video content not available in all regions. Video content subject to availability of YouTube Kids app. Books content requires the Play Books app. Availability of apps, books, and video content may change without notice. Google Assistant not available in Google Kids Space. Google Kids Space requires a Google Account for your child. Parental controls require the Family Link app on a supported Android™, Chromebook, or iOS device.

- Feature with \*\* means that only one option listed under the feature can be configured on selected models. Please refer to the model configuration for specific information.
- Feature with \*\*\* means that one or more options listed under the feature can be configured on selected models. Please refer to the model configuration for specific information.
- Lenovo reserves the right to change specifications or other product information without notice. Lenovo is not responsible for photographic or typographical errors. LENOVO PROVIDES THIS PUBLICATION “AS IS,” WITHOUT WARRANTY OF ANY KIND, EITHER EXPRESS OR IMPLIED, INCLUDING THE IMPLIED WARRANTIES OF MERCHANTABILITY OR FITNESS FOR A PARTICULAR PURPOSE. Some jurisdictions do not allow disclaimer of express or implied warranties in certain transactions, therefore this disclaimer may not apply to you.
- The specifications on this page may not be available in all regions, and may be changed or updated without notice.

